

ENDURIS
 7167 OLD KINGS ROAD NORTH
 JACKSONVILLE, FL 32219
 TOLL FREE: 1-888-329-7428
 PHONE: (904) 378-1884
 FAX: (904) 421-3312
 www.enduris.com

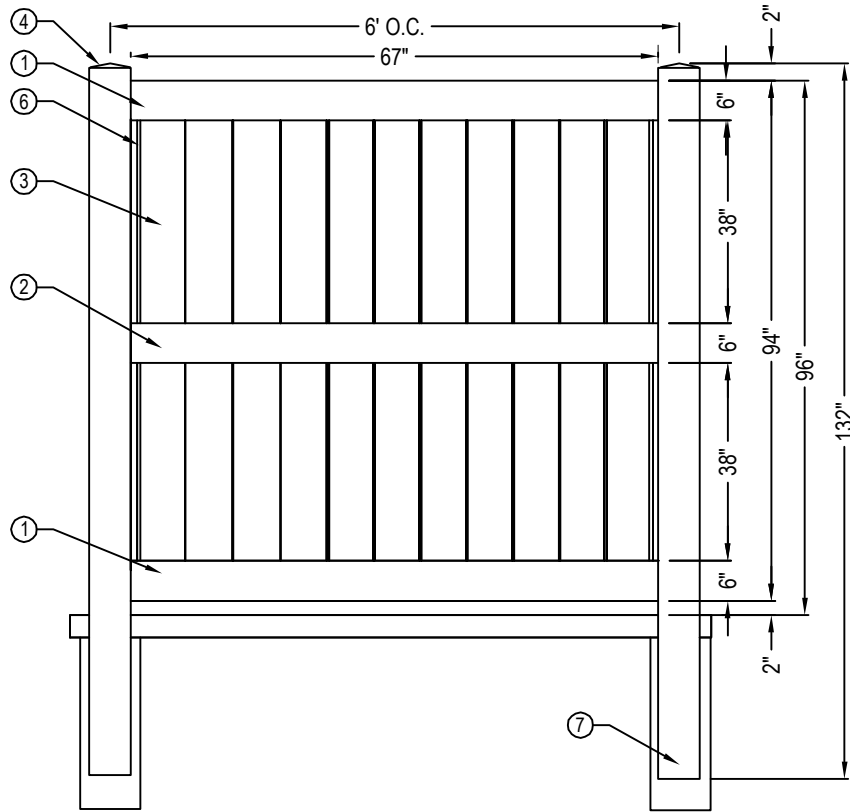

FRONT ELEVATION

| LEGEND: | SIZE: | PART # | QTY. |
|--------------------------|----------------------|-----------|------|
| ① SKIVED & TABBED 1 SIDE | 2 X 6 X 71.5" | E-AG-01 | 2 |
| ② SKIVED & TABBED 2 SIDE | .875 X 6.050 X 60.5" | E-AG-01 | 1 |
| ③ AR T & G | .875 X 6 X 41.5" | E-AR-04 | 22 |
| ④ 5 X 5 CAP | 5 X 5 | A-C-W-053 | 2 |
| ⑤ REINFORCEMENT | 2 X 6 | A-R-M-101 | 3 |
| ⑥ | | AW-03 | 4 |
| ⑦ .150 WALL ROUTED POST | 5" X 5" X 132 | AA-02 | 2 |

NOTES:

- (APPLIES TO ALL STYLES, EXCLUDING OPEN PICKET AND SURFACE ATTACHED) ANYTHING OVER 72" SPAN, LESS THAN .100 WALL OR NON-WHITE REQUIRES REINFORCEMENT
- INSTALLATION TO BE COMPLETED IN ACCORDANCE WITH MANUFACTURER'S SPECIFICATIONS.
- DO NOT SCALE DRAWING.
- THIS DRAWING IS INTENDED FOR USE BY ARCHITECTS, ENGINEERS, CONTRACTORS, CONSULTANTS AND DESIGN PROFESSIONALS FOR PLANNING PURPOSES ONLY. THIS DRAWING MAY NOT BE USED FOR CONSTRUCTION.
- ALL INFORMATION CONTAINED HEREIN WAS CURRENT AT THE TIME OF DEVELOPMENT BUT MUST BE REVIEWED AND APPROVED BY THE PRODUCT MANUFACTURER TO BE CONSIDERED ACCURATE.
- CONTRACTOR'S NOTE: FOR PRODUCT AND COMPANY INFORMATION VISIT www.CADdetails.com/info AND ENTER REFERENCE NUMBER 4905-021.

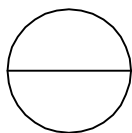

MIRAGE PVC FENCE PANELS

8' X 6"W MIRAGE CAPPED PVC FENCING